

# TFI Report 480238-01

## Sound Absorption

### Customer

IVC NV  
Nijverheidslaan 29  
8580 Avelgem  
BELGIUM

### Product

textile floor covering  
Adaptable

This report includes 2 pages and 1 annex(es)

### Responsible at TFI

-Senior Engineer-  
Dr.-Ing. Heike Kempf  
Tel: +49 241 9679 171  
[h.kempf@tfi-online.de](mailto:h.kempf@tfi-online.de)

**Aachen, 12.03.2018**

Dr. Alexander Siebel

- Head of the testing laboratory -

The present document is provided with an advanced electronic signature



This report only applies to the tested samples and has been established to the best of our knowledge. Only the entire report shall be reproduced. Under no circumstances, extracts shall be used. Furthermore, we apply the "General Terms and Conditions for the Execution of Contracts" of the TFI Aachen GmbH, also with regard to the order execution.

## 1 Transaction

Test order	sound absorption according to EN ISO 354
Order date	05.02.2018
Your reference	S. Roose
Product designation	Adaptable
TFI sample number	18-02-0016

## 2 Product Specification

Type of manufacture	tufted
Type of surface	loop pile
Backing	heavy backing
Pattern	tonal effect without pattern
Colour	grey, light grey, white

View



Thickness [mm]	7.0*
Area density [g/m <sup>2</sup> ]	4150*
Type of delivery	tiles

\*customer information

## 3 Results

Sound absorption	$\alpha_w = 0,15$ (H)
------------------	-----------------------

## 4 Annexes

Sound absorption	SA 480238-01 <sup>a</sup>
------------------	---------------------------

The annexes marked <sup>a</sup> are based on tests accredited in accordance with EN ISO/IEC 17025.

# Annex SA - Sound Absorption Coefficient

## 1 Transaction

Product designation	Adaptable
TFI sample number	18-02-0016
Testing period	19.02.2018

## 2 Test Method / Requirements

EN ISO 354:2003	Measurement of sound absorption in a reverberation room
EN ISO 11654:1997	Sound absorbers for use in buildings – Rating of sound absorption
Deviation from the standard	None

## 3 Remarks

None

## 4 Measuring Operation

Test noise:	broadband pink noise
Receive filter:	third octave band filter
Measurement:	2 loudspeaker positions 6 microphone positions

## 5 Laboratories

Test rooms:	laboratory of the TFI Aachen GmbH, Hauptstr. 133, 52477 Alsdorf, Germany
Test method:	reverberation room method
Volume:	211 m <sup>3</sup>
Total surface:	213 m <sup>2</sup>
Floor plan:	trapezoidal
Reflectors:	6 aluminium plates 1.0 m x 2.0 m 7 plywood boards 1.5 m x 1.3 m 1 aluminium plate 1.8 m x 0.9 m

## 6 Measuring Devices

Real time analyser:	Norsonic Nor140, SN: 1406926
Microphone:	Norsonic Type 1209/21134
Loudspeaker:	2 dodecahedrons

## 7 Evaluation

The decay curves are determined using the interrupted noise method. Several decay curves measured at one microphone and/or loudspeaker position are averaged in order to reach a sufficient reproducibility. The reverberation time of the room is expressed by the arithmetic mean derived from the total number of all reverberation time measurements in each frequency band.

The equivalent sound absorption area of the test specimen  $A_T$  is calculated as the difference between the equivalent sound absorption area of the reverberation room with test specimen  $A_2$  and the equivalent sound absorption area of the empty reverberation room  $A_1$  without test specimen.

The equivalent sound absorption coefficient  $\alpha_s$  describes the ratio of the equivalent sound absorption area  $A_T$  of a test specimen divided by the area of the test specimen.

The evaluated sound absorption coefficient  $\alpha_w$  is a single-number frequency-independent value which equals the value of the reference curve at 500 Hz after shifting it.

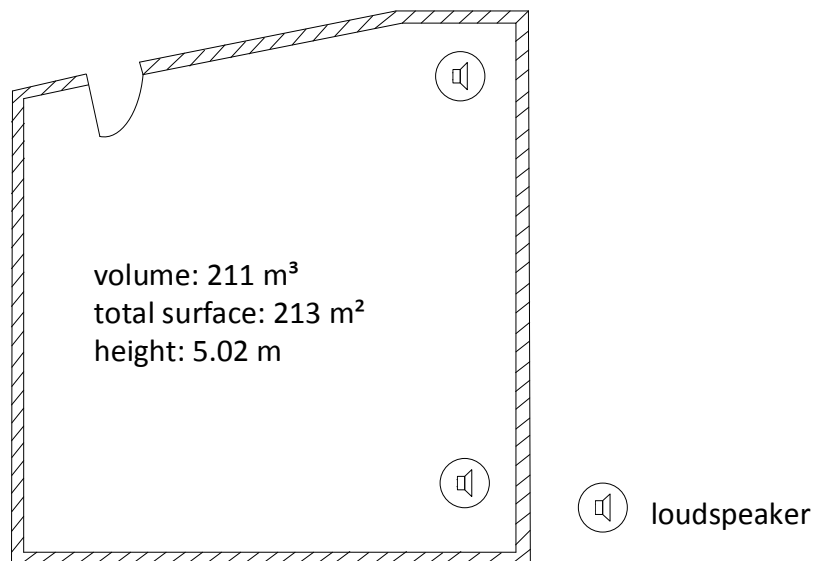

*Drawing reverberation room*

Measurement of sound absorption coefficient in a reverberation room

Annex SA – Sound absorption

Page 1 of 2

TFI sample no.: 18-02-0016

Testing period: 19.02.2018

Construction: -  
(from top to bottom)

Product name: Adaptable

Reverberation room / without

Relative humidity: 35,6 %  
Temperature: 19,5 °C  
Barometric pressure: 100,2 kPa

Reverberation room / with sample

Relative humidity: 35,6 %  
Temperature: 19,5 °C  
Barometric pressure: 100,2 kPa

Surface area: 12,00 m<sup>2</sup>  
Room volume: 211,0 m<sup>3</sup>  
Total room area St: 213 m<sup>2</sup>

Frequency f [Hz]	$\alpha_p$ Oktave
100 125 160	0,00
200 250 315	0,00
400 500 630	0,05
800 1000 1250	0,20
1600 2000 2500	0,25
3150 4000 5000	0,30

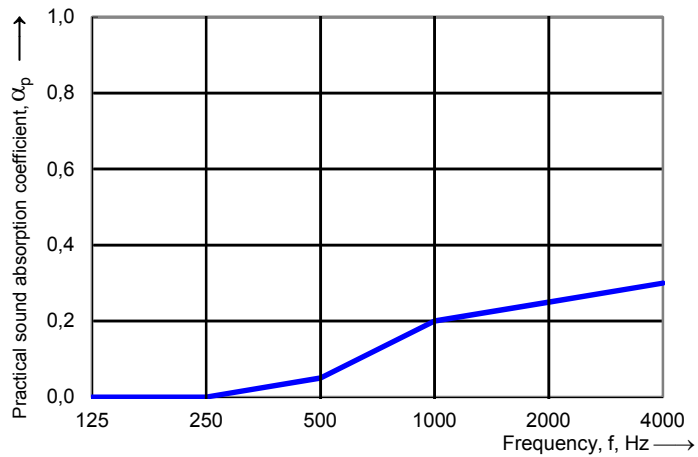

Weighted sound absorption coefficient according to ISO 11654

$$\alpha_w = 0,15 \text{ (H)}$$



# Sound absorption according ISO 354

SA 480238-01

Measurement of sound absorption coefficient in a reverberation room

Annex SA – Sound absorption

Page 2 of 2

Weighted sound absorption coefficient according to ISO 11654

$$\alpha_w = 0,15 \text{ (H)}$$

Surface area: 12,00 m<sup>2</sup>  
Room volume: 211,0 m<sup>3</sup>  
Total room area St: 213,0 m<sup>2</sup>

Frequency [Hz]	$\alpha_p$	$\alpha_s$	A [m <sup>2</sup> ]	T1 [s]	T2 [s]
50		0,00	0,0	7,21	7,20
63	0,00	0,02	0,2	8,15	7,79
80		0,02	0,3	9,59	8,87
100		-0,02	-0,2	9,68	10,41
125	0,00	0,03	0,4	6,79	6,32
160		0,01	0,1	6,06	5,94
200		0,00	0,0	6,48	6,45
250	0,00	0,01	0,1	6,28	6,21
315		-0,02	-0,2	5,47	5,68
400		0,05	0,6	5,89	5,30
500	0,05	0,08	0,9	6,18	5,29
630		0,07	0,9	6,07	5,23
800		0,13	1,6	5,65	4,48
1000	0,20	0,14	1,7	5,31	4,20
1250		0,26	3,1	5,24	3,56
1600		0,31	3,7	4,82	3,15
2000	0,25	0,25	3,1	4,31	3,11
2500		0,25	3,0	3,56	2,70
3150		0,25	3,0	2,81	2,25
4000	0,30	0,28	3,4	2,16	1,78
5000		0,32	3,8	1,56	1,33

Reverberation room / without sample:  
Relative humidity: 35,6 %  
Temperature: 19,5 °C  
Barometric pressure: 100,2 kPa

Reverberation room / with sample:  
Relative humidity: 35,6 %  
Temperature: 19,5 °C  
Barometric pressure: 100,2 kPa

TFI sample number: 18-02-0016

